



**Wood Stove
6kw and 8kw
Ardor Range**



Please read these instructions carefully before installation and use, and retain them for future reference

Updated: 27 Feb 2024

Congratulations on your purchase of an Infiniti Fires Freestanding wood stove

- This wood burning stove is designed and built to give you many years of service producing large quantities of heat at minimal cost.
- Please bear in mind that this stove burns at temperatures approaching 1000 degrees C. Operating and flue temperatures are therefore way in excess of those produced by open wood fires.
- It is important that the instructions detailed in this booklet are followed to ensure the correct and safe functioning of this appliance.
- Where possible we strongly recommend that you use a skilled installer trained in this type of product to install the stove and flues.

Fuel

- This unit is intended as a wood burning unit. It will not burn anthracite or coal effectively and should these fuels be used the corrosive nature of the fuel will cause damage to the fire.
- For best results the wood should be well seasoned so that it is dry. A water content of 16 to 20% is ideal for burning. This means typically 6 to 9 months of storage after the wood was cut down.
- A good clue as to how seasoned wood is; is to look for natural cracking of the wood where it has been sawn through. If you see cracking, then the wood is ready to burn.
- When rain falls onto wood that has been well seasoned, it will typically penetrate only a few mm into the wood. It is best to leave this wood in a dry place for a week or so for the water to evaporate off.
- Burning wood that is too wet will result in the fire under-performing in terms of heat output and can damage the unit and/or flueing system.



Unseasoned VS seasoned

Safety Information

Minimum distances to walls / combustible material.

- The stove is designed as a convection stove. This means that the outside surfaces at the rear, sides and top are of a double skin construction. This allows an air movement between the two sheets of steel which cools the steel and produces a relatively cool outer skin temperature. Generally, with a good fire going inside the unit, the outer steel surfaces on the sides and rear will range between 30 and 130 C.
- This allows you to put the fire closer to walls and combustible material than stoves with just a single outer skin (radiant fires). It is recommended that the minimum distance to a painted brick wall at the rear or side of the fire is 100mm. For face brick walls this distance can be reduced to 50mm.
- Caution should however be taken in that although the face brick will take the heat well, the mortar between the bricks may show some signs of cracking. For dry skin walls or wooden walls, it is recommended that this distance be increased to at least 200mm.
- The bulk of the intense heat of the fire will come out through the glass window. It is recommended that sensitive items such as leather furniture, veneered wood, etc. if put directly in front of the glass window be at least 1.5m from the glass and at least 1m away for less sensitive items such as wooden tables and chairs.
- If building the unit into a recess it is recommended that there is a clearance of at least 300mm above the unit to allow the heat to escape the recess into the room. Lowering this height will start to inhibit air flow and increase the temperature of the material used to make the recess.
- The glass in the door will reach temperatures in the mid 400°C. We recommend that when small children are present a fire screen be used to prevent the glass being touched.
- When the door is open hot pieces from the fire may drop out onto the floor.
- As the fire can burn at temperatures in the mid to upper 900°C it is likely that anything falling onto the floor could damage or ignite any combustible surface on which it falls. It is strongly recommended that a non-flammable hearth be positioned below the wood stove.

Floor Surfaces

- The base of the optional legs and/or wood storage box does not get hot. This means that the wood stove in one of these variants can stand on any sound support.
- Convection wood stoves without legs / wood storage should be installed on a non-flammable hearth.
- However, when the door is open hot pieces from the fire may drop out onto the floor. As the fire can burn at temperatures in the mid to upper 900C it is likely that anything falling onto the floor could damage or ignite any combustible surface on which it falls.
- It is strongly recommended that the unit be positioned on a heat resistant base (tiles, concrete, steel, granite, toughened glass...etc) of adequate size to prevent this occurring.

Flue Exits

- Our 6 & 8kw Ardor range units are designed to be either a top or rear exit flue system.

Flue Installation

- There are various flueing systems available in South Africa that will work very well with this unit. They all have slightly different fittings, flashings and ceiling collars.
- Talk to the shop that is supplying you this Infiniti Unit and their choice of flueing system and get an adequate description of what you need and how to install that flueing system if necessary.
- Our 6kw use a 125mm & our 8Kw use a 150mm diameter flue. The flue slides inside the flue collar as far as it will go. Seal the gap between the flue and collar with fire cement. Sit the unit in the desired position taking into account the safety clearances detailed above.
- It is recommended that the minimum distance from the flue to any flammable material in the roof is 200mm or more. This includes beams and brandering.
- If you have less than 200mm you need to either move the unit, use bends to obtain a greater clearance between the flue and the beam, or as a last resort cut the beam. If the last option is done, you need to look carefully at the roof support before doing this and ensure you can retain adequate structural integrity in that roof section.
- It is essential that the hot flue inside the ceiling space is adequately lagged in a high temperature ceramic wool to prevent flammable material in the roof catching alight.
- Ordinary glass fibre loft insulation is not high temperature and will melt with contact with high heat, rendering its ability to insulate the flue non-existent.
- In the event that the flue is exiting through a brick chimney it is essential that the chimney is adequately closed around the flue to prevent heat losses from the roof occurring through this cavity.

Ensure wood stove is level

- It is best practise to ensure that the platform/floor surface the wood stove will stand on is as level and stable as possible.
- When the wood stove is positioned in place and is not entirely level, the bottom leg adjusting bolts can be used to assist in making small adjustments in levelling the unit.

General Tips on Flueing Systems

Creosote

- In normal open fires small particles of un-burnt oil/sap, water and soot from the wood being burnt are vented up and out of the chimney. The high velocity and volume of air going up the chimney carries these items for the most part safely away from the chimney.
- In a Closed Combustion Wood Stove, the flow of air through the unit is substantially reduced. The particles still go up the chimney and if the chimney is hot are safely vented out of the top of the chimney.
- However, if the chimney is cold these particles coalesce into a brown liquid called in the trade "creosote". This typically happens if the hot steel flue is exposed to cold weather conditions over a reasonable length and/ or if the stove is running on slow burn overnight. i.e., the air controls mostly closed so that the stove keeps burning slowly overnight.
- This liquid will run back down the flue towards the fire until the liquid gets hot enough to evaporate and go back up the chimney. The remaining residue will attach itself to the inside of the flue.

- Creosote is highly corrosive and will attack the inside of the flues. Flue selection should take this into account.
- Creosote can build up inside the flue and form a highly flammable fuel source inside the flue. If this ignites inside the flue, temperatures in the flue will be extreme and could easily catch a roof alight unless adequate precautions are taken to deal with this heat.

Minimizing and Dealing with Creosote

- To cope with the potential of the creosote running back down the flue, the working flues need to have the male joints between flues facing downwards. This will force the liquid to keep running down inside the flue rather than exiting the flue on every joint.
- Creosote can be minimized by keeping the working flue hot. The best way of achieving this is to have an insulated flue to the top of the chimney. An insulated flue has an inner working flue encased in a high temperature insulation material.
- Creosote is particularly aggressive on bends in the flue where creosote can pool. Use Stainless Steel bends or bends that are enamelled inside and out to reduce this corrosive attack.

Lighting the Stove

Top-down method

- Start with a good base. Place the larger pieces of wood at the bottom of the firebox. About 100mm - 150mm in width. Place a second layer of smaller logs, about half to three quarter of the size of the main pieces. Place a third layer of even smaller logs on top of the second layer. Not more than 25-50mm in width.
- Spread some fine kindling on top of the third layer. Add a few pieces of firelighters or newspaper on top/in between the kindling, spread out evenly across.
- Light a few pieces of the newspaper and/or firelighters and close the door with the air control fully open (to the right-hand side).



Air control

See fig. 1

- Once the fire is going well you have the option of adjusting the air inlet controls. These work in a similar fashion to the accelerator pedal on a car. If you want heat, leave the controls open. If you want to reduce heat, start to close the air inlets.
- The lower control adjusts air flow to the lower and rear air vent. If you are adjusting downwards in heat, close or partially close this control first.
- The upper air inlet adjusts air flow onto the top of the glass door. Closing this control too much will result in the glass going black. It is suggested for slow burn, (where you have the fire going well, full of wood and you wish to burn it through the night), you have the lower control fully closed (to the left) and the top control about 80% closed.
- With good quality wood, a full firebox of wood and the controls in these positions our inserts are capable of burning in excess of 10 hours on a load of wood.
- When opening the door to refuel the fire, open the door slowly to prevent creating a vacuum and pulling smoke into the room. Upon refuelling the fire, it may be necessary to open the air vents to get the new wood burning well.
- Only operate the top control once the lower control is in the fully closed position. It is suggested to open all air controls when restoking the fire.

Vermiculite Panels

- The Infiniti Fires firebox has compressed vermiculite panels in the unit. These function to assist in raising the combustion temperature of the fire to achieve a high temperature combustion which is both environmentally friendly and highly efficient.

With the heat of the fire, they will develop hair line cracks. This will not stop the panels functioning and is expected as part of normal fire use. Care should be taken not to throw wood into the fire as this will cause excessive damage to the panels.

Cleaning the door glass

- With operation, particularly if you have burnt wood too slowly the door glass will blacken. This is normal. To clean the glass, you can relight the fire. At normal operating temperatures with the air vent fully open, the glass will pretty much clean itself as the air wash runs over the glass.
- If there are any particular persistent marks on the glass these can be removed manually. When the fire is cold, dip a moist cloth into the wood ash at the bottom of the fire. Smear the ash onto the glass and rub well. The ash is slightly abrasive and will cut through the dirt easily. Wipe the glass clean with a clean cloth.
- Do not use any chemical cleaners on the glass. Certain chemicals (particularly ammonia) react with heat and attack the glass. A residue of ammonia left on the glass will make the inside of the glass pitted and white in colour on the first burn, as it eats into the glass.

Cleaning out the ash

- This unit is intended to be a continuous burner. You can either keep refilling the unit with wood so that it keeps on burning or you can make the next fire on top of the previous fires' ash. The fresh firewood will compress the ash.
- Due to the high combustion temperature, there will be minimal quantities of ash made.
- The section at the base of the fire has been made deliberately deep to hold this ash. Dependent on the type of wood you are burning the fire will need cleaning out every 1 to 3 weeks. It is best to do this when the firebox is cold.

Servicing

- For the correct and efficient operation of this wood stove it is important that:
 - The rope maintain an airtight seal into the firebox.
 - The vermiculite panels provide adequate insulation to prevent damage to the steel firebox.
 - The flue remains fully open to allow smoke to easily exit the stove.
- If you can see damage to any of these components, or the stove smokes into the room, more than normal, when the door is open and the fire lit, the unit requires servicing.
- Contact the shop you bought this unit from and request a service.

Firescreen

- The firescreen acts as a form of a safety net if someone had to try touch the glass door.
- It also reduces the heat projected out the front of the fireplace, for installations where you may have the fireplace facing furniture.
- Whilst the screen will most certainly reduce the heat projected through the glass and lessen the burn should someone try touch the glass, it must be noted that this is a precautionary measure and injury, or damage could still take place.
- Installation of the firescreen is as simple as sliding the firescreen over the door, ensuring the handle goes through the slot in the firescreen frame, and then securing it to the wood stove door with 4 x button head screws (supplied with the firescreen).

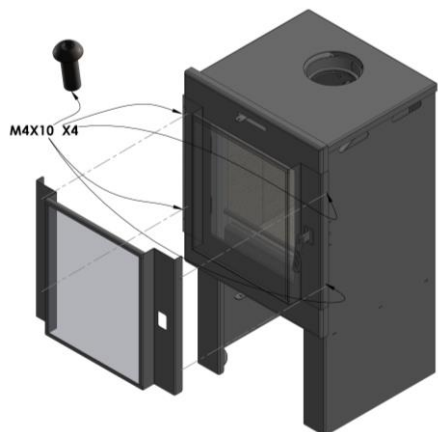

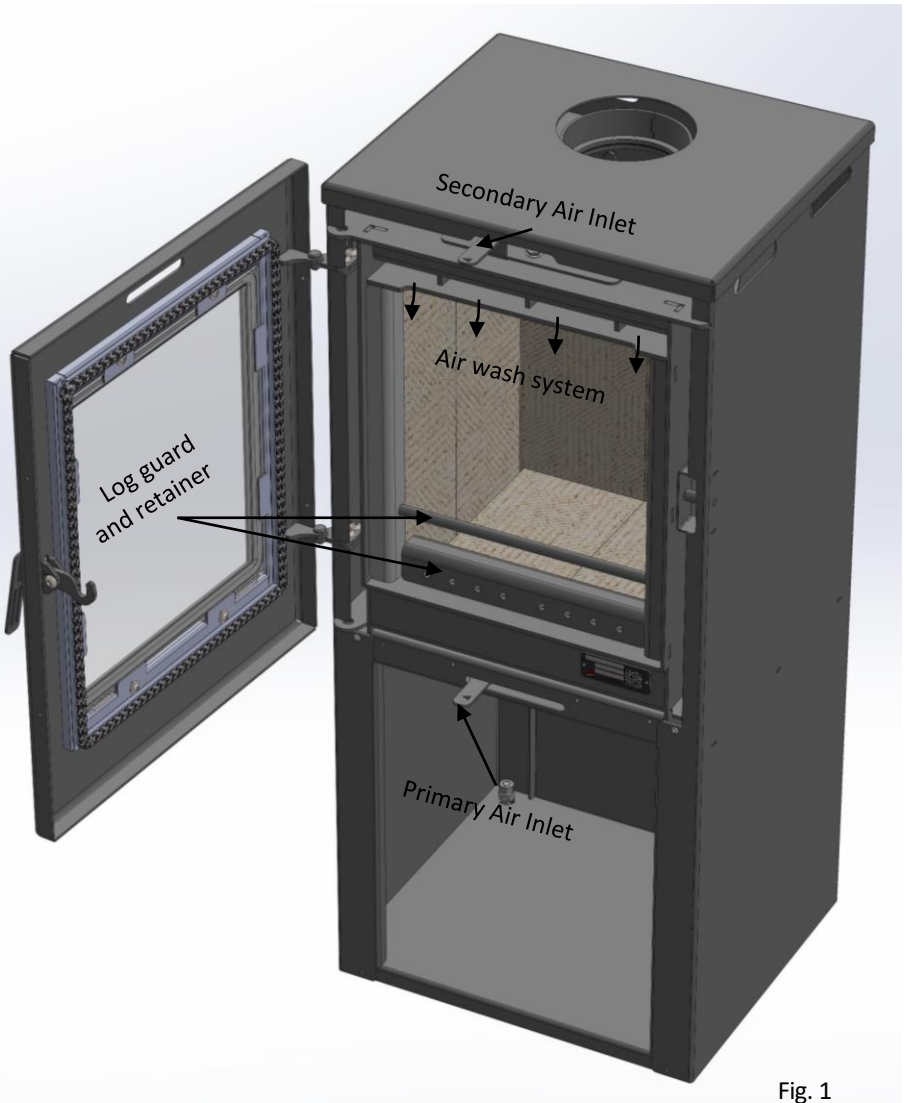
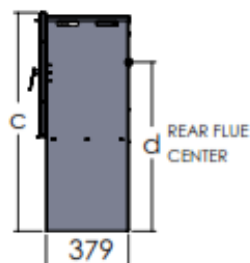

Fig. 1

Schematics



WOOD STORAGE



TAPERED LEGS

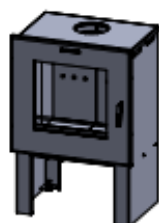
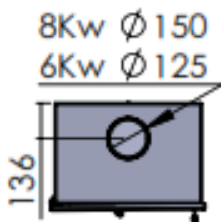
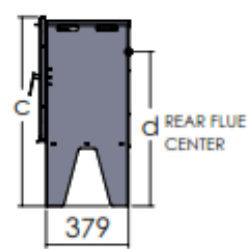

NARROW LEGS

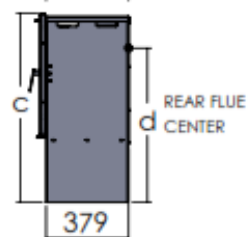

	a	b	c	d
6Kw WOOD STORAGE	468	434	1003	755
6Kw TAPERED LEG	468	434	868	708
6Kw NARROW LEG	468	434	868	708
8Kw WOOD STORAGE	588	554	1003	755
8Kw TAPERED LEG	588	554	868	708
8Kw NARROW LEG	588	554	868	708

WOOD STOVE WARRANTY

Infiniti Fires warrants the soundness of their Wood Stoves for the period after purchase as detailed below.

Steel Fireboxes, Outer Convection Bodies, Doors and Legs

5 years

Items excluded from warranty.

Items in the flame path, such as vermiculite panels, rope seals and glass are not covered by a warranty, as these items are particularly prone to damage in the event that the Wood Stove is incorrectly installed, used or maintained.

To validate the warranty, the customer must produce;

- Proof of Purchase, so that the purchase date can be verified.

OUR WARRANTY DOES NOT COVER

- Corrosion where the product has been installed in a location or manner such that, it is subject to water ingress or sea influence.
- Damage to the Appliance, where it has not been installed in compliance with its Instruction Manual.
- Damage caused by the Appliance operating outside of its normal working state.

If a claim arises under this warranty, Infiniti Fires will, at its sole discretion either repair or replace the affected unit.

As Infiniti Fires does not do the installation of these units, it accepts no responsibility for the installation thereof.

Infiniti Fires will not be responsible for any consequential damage arising from the use of its units.

Dealer's Stamp

Infiniti Fires

P.O. Box 520 Fourways 2055

Email: info@infinitifires.co.za

Web: www.infinitifires.co.za