

FREESTANDING

CONVECTION BOX

14 KW SINGLE SIDED



A NEW GENERATION IN HEATING



INFINITI 14 KW CONVECTION BOX C/W REAR GLASS

NEW FEATURES

1 TOUCH AIR CONTROL

Traditionally wood stoves have two air control levers - one to control the primary air brought into the base of the fire - and one to control air brought into the top of the fire. This is to improve combustion efficiency, lower emissions into the atmosphere, and keep the door/glass clean and cool. There is some thought involved in how to adjust these controls correctly for best effect combustion.

Our 14 Kw single sided stoves utilise our **1 Touch Air Control**. This single air control is located at the bottom of the door, where it is much cooler to the touch. It easily adjusts air flow in the correct proportions to the top, rear and base of the stove, to maximise efficiency and ensure clean burning - making these units much simpler to use than many other wood stoves.

CHOICE OF GLASS

Our 14 Kw single sided stoves come in a choice of a Clear Glass at the rear of the door or a Black Border Glass located at the front of the door, for a more sophisticated look.

PULL OUT TABLE

When lighting your fire or cleaning out the ash, pull out this table to hold your kindling, wood, and matches and to catch any particles/ash dropped. Simply slide the table in after use to hide any dropped particles/ash until such time that the table can be cleaned.

AIR INLET RESTRICTOR

Easily set to prevent over burning when installed with a long chimney or in high wind areas.



INFINITI 14KW CONVECTION BOX CW BLACK BORDER GLASS & TAPERED LEGS



INFINITI 14KW CONVECTION BOX CW BLACK BORDER GLASS & SLIMLINE LEGS

FREESTANDING

CONVECTION BOX

14 KW SINGLE SIDED



A NEW GENERATION IN HEATING

INFINITI 14 KW CONVECTION BOX C/W BLACK BORDER GLASS & LONG TAPERED LEGS



INFINITI 14 KW CONVECTION BOX C/W BLACK BORDER GLASS & WOOD STORAGE BOX



HEATING CAPACITY

14 Kw ▶ 560 m³

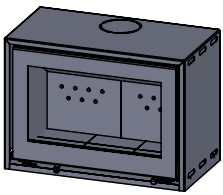

CONVECTION UNIT

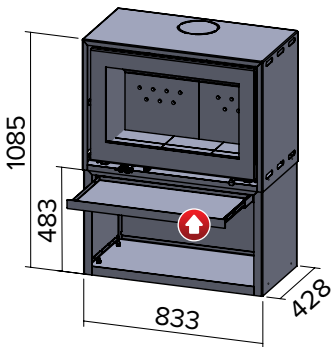
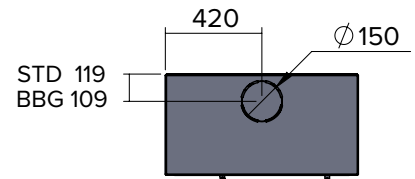
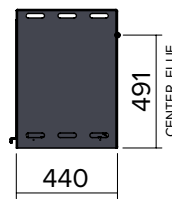
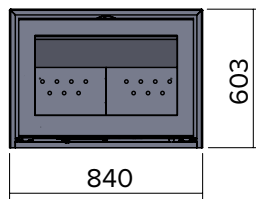

C/W WOOD STORAGE BOX

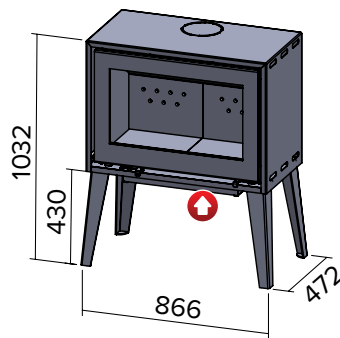

C/W LONG TAPERED LEGS

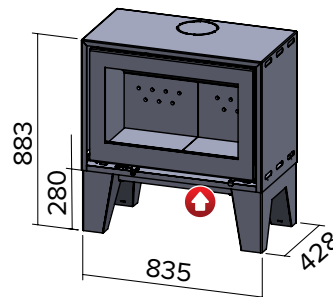

C/W TAPERED LEGS

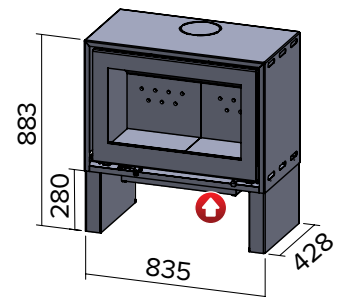

C/W SLIMLINE LEGS

NEW PULL OUT TABLE

14 KW | FREESTANDING | CONVECTION | 1 TOUCH AIR CONTROL | AIR INLET RESTRICTOR | 150 MM DIAMETER FLUE | TOP OR REAR EXIT

Please refer to the **FEATURES & SAFETY REQUIREMENTS** common to all our wood stoves