

WALL MOUNTED

CONCEPT MANTLE



A NEW GENERATION IN HEATING



CONCEPT MANTLE GAS FIRE

CHOICE OF COLOURS

WHITE

CREAM

RED

These units require no messy or costly building work. Instead they simply bolt to the wall and connect to a gas supply, providing an easy and time saving installation.

Our wall-mounted units are designed to be installed on a wall, out of reach of small children, making them an ideal choice for families with young kids.

The Infiniti Concept Gas Fire is designed to be hung on a wall or, with the addition of top and bottom sections, installed as a modernistic mantle unit, making it ideal for enhancing modern architectural styles.

The top and bottom sections of the mantle are available in a choice of three colours, as detailed. If you prefer your own colour scheme, these sections can be painted by your installer to your individual preference.

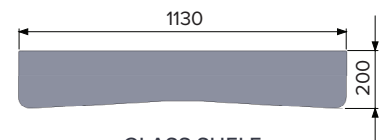
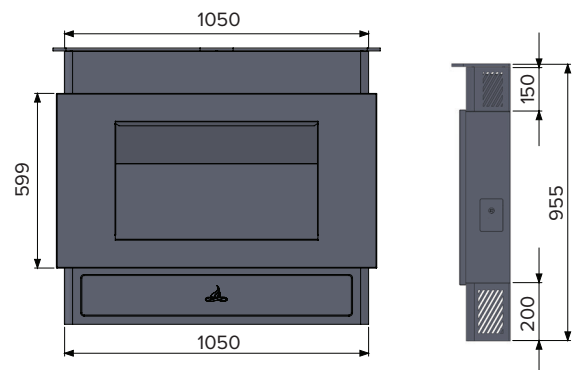

GLASS SHELF

2026 EDITION

This unit is supplied with a glass screen and mounting brackets for optional installation

UNIT	HEAT OUTPUT Kw	HEATING CAPACITY m ³	GAS CONSUMPTION g/hr		LEGAL MIN ROOM SIZE m ²	PERMANENT VENTILATION REQUIRED IF ROOM IS SMALLER THAN LEGAL ROOM SIZE cm ²
			LO	HI		
CONCEPT 200	5	200	150	300	75	2 x 98
CONCEPT 300	7	300	250	490	125	2 x 160