

This appliance conforms to the requirements of SANS1539  
LPGSASA Permit Number: 1011-8/2-RSA-17-A  
Counter Top Model Number: MB2C



**700, 1000, 1200 & 1500  
Multifunction Built-in Braai  
Solid fuel or gas grill options**



Please read these instructions carefully before installation and use, and retain them for future reference

Updated: 20 May 2026

## 1. Introduction

- Thank you for purchasing your new Firefox Multifunction Braai c/w either gas or solid fuel (charcoal or wood) inners.
- This appliance is designed to give the user years of trouble free and efficient service.
- Please read these instructions carefully before installation and use of this appliance and retain them for future reference.

## 2. Intended Use

- This appliance is intended for installation on an open-sided covered patio, where there is a roof overhead to protect the braai from rain and a free flow of air across the patio. This free flow of air is essential for the correct and safe operation of this appliance.

## 3. Solid Fuel braais

- When used purely as a solid fuel braai (wood or charcoal being burnt) the braai will require adequate air feeding into the braai to allow good smoke extraction up the chimney. Open sided covered patios will provide an abundance of air.
- If the patio/area where the braai is to be installed has enclosed sides (i.e. patio/stacking doors have been installed enclosing the patio or the braai is to be installed in an internal room) adequate external air will need to be provided, to enable the braai to function well. Typically, a well opened window or door will provide adequate air for the smoke from the braai to extract well.

## 4. Gas Braais

- Gas braais have a similar air requirement to a solid fuel braai to enable the chimney to function well. In addition, there is a legal requirement that gas braais can only be installed where there is a free flow of air around the braai, that is capable of dispersing any gas leak should the gas grill has been accidentally left, with a control valve in the open position and unlit.
- It is therefore unsafe and illegal to install this braai, with a gas grill option, inside an enclosed patio or internal room.

## 5. Outside Installation

- This appliance may be installed in a garden or similar setting, where it is exposed to the elements.
- Solid Fuel and gas options are legal and safe to install in an outdoor setting. However, the installer should take adequate precautions to protect the braai steel from rust.
- These precautions could entail;
- Upgrading the braai to a more durable steel type

Coating the exposed steel in a water-resistant paint.

- Installing a roof overhang above the braai to minimise rain being in contact with the braai steel.

## 6. Installing the Braai Box into a new brick structure

### 6.1 Braai Body

- Bolt the removable flue gather supplied with this unit to the top of the braai box, with the joint for the first flue pointing upwards.
- Make sure the Electrical Motor housing supplied with this unit has been bolted to the outside of the braai box.
- The braai box is intended to be built into a non-combustible structure. This structure must be capable of handling the heat created by the braai and the weight of the braai. Typically, this structure is created out of brickwork.
- The steel braai box should ideally be built in simultaneous with construction of the brick structure, so that there is no additional work or patching to be done later.
- Generally, a person about 1.8 m in height will find it comfortable braaiing with the braai grid at about 1.0 to 1.1 m above floor level. The base of this braai box should be built in between 700 to 800 mm above floor level to achieve this desired cooking height.
- It is often desirable to have a cupboard space below the braai to hold wood/charcoal OR a gas bottle (where the braai is gas operated). Provision should be made in the brick structure for a cupboard if desired.
- The top of the cupboard space should be covered over with concrete lintels prior to building in the braai box above this. Note optional steel cupboard doors may be obtained from us that can tidy up this cupboard space.
- Level the structure the braai will sit on, PRIOR to positioning the Braai Box in its built-in position.
- Position the braai box on the brick structure, such that the face frame of the braai protrudes in front of the brick/plaster wall. This will enable the frame to expand and contract with heat during the braaiing process without damage to the brickwork.
- Cover the face frame and inside the braai to avoid damage being done to the braai/paint during construction.
- The braai is supplied with a roll of fibreglass insulation. Cut this insulation into strips to clad the exterior of the braai box on the rear, sides and top. Brickwork should be installed against this insulation to hold it in place.
- Typically, the insulation creates a distance of 25 to 30 mm between the brickwork and the steel braai box.

- This insulation/gap will enable the braai box to expand and contract when in use and will minimise heat transfer into the brickwork. DO NOT put insulation below the braai base. It needs a solid stable base to stand on.
- Allow for installation of electrical conduit and cable to the light fitting, located at the top LHS of the unit. In addition, conduit/cabing to the electric motor housing, in the event you have purchased our optional spit motor OR may want to do so in the future.
- A concrete lintel should be placed over the braai box to support the front wall of the structure being built. The Lintel should not touch the steel of the braai box, but rather rest on the brickwork to the LHS and RHS of the braai and have insulation between the lintel and the top of the braai box.
- Install the first length of flue over the spigot provided on our flue gather. Join other flues as required using the male/female joints to connect together. Continue with brick work to the required height.

## 6.2 Flues

- The minimum recommended length of flue for good smoke extraction on this unit is 2.4 m.
- Typically, if the flue exits through a roof 600 mm or closer to the ridge of the roof, the flue should extend at least 600 mm higher than the ridge.
- If the flue exits further than 600 mm away from the ridge of the roof, the flue should extend 1m above the point of exit through the roof.
- High angle/pitch roofs will require a greater height of flue above the roof.
- If there are buildings, tall trees or other objects near the top of the flue the length of the flue will need to be increased to take these objects into account.

## 6.3 Cowl/Waterproofing

- A cowl will need to be installed at the top of the chimney, to prevent rainwater coming down the flue into the braai and creating damage to the braai and its components.
- In areas of the country that have typically non windy conditions a fixed cowl is adequate for a braai.
- When a braai is installed through or near thatch or the area has typically windy conditions a rotating cowl works better at smoke extraction and should be used.
- Note the point of exit of the flue through a roof or at the top of a brick chimney will require some waterproofing to prevent water ingress to the exterior or interior of the flue.

• Water running down the outside of the flue will create damage to the flue and the house. Water running down the inside of the flue will damage the flues and the braai, braai components.

## 6.4 General

- Do not allow water (typically rainwater) during the construction process to pond for any length of time on the base of this braai. It will corrode the base.
- Be cautious if using Mortar Lift or similar on the brick structure around the braai. Mortar lift is VERY corrosive to steel. Immediately after using Mortar Lift wash the braai with soapy water and rinse to prevent/minimise damage to the steel work.
- On completion of building the exposed portions of the braai box should be cleaned with soap and water then rinsed off. When dry the exposed steel of the braai box should be repainted with the aerosol can of paint supplied with the unit.
- Once this is complete and dry, install the charcoal or gas components of this braai and you are complete.
- It is good practice to allow the paint to dry for 4 hours and the brickwork to dry for 4 days prior to braaiing.

## 7. Gas Grill Installation into 1000 MFB

### 7.1 Important Information for the user

- This gas appliance may only be installed by a Registered Gas Installer. All registered gas installers are issued with a drivers license size card, displaying their registration number, the type of gas they are registered to work on, and the expiry date of their registration. Ask to be shown this card before allowing the installation work to commence. Make a note of the Installer registration number, as well as verify that the gas type they are registered to work with, complies with the gas type you will be using. If there is any doubt on the registration of your chosen installer log onto [www.saqccgas.co.za](http://www.saqccgas.co.za) to look up their details.
- Upon completion of the installation, the installer is legally required to explain the operational details of the appliance, together with the safety instructions, and is required to issue you a Certificate of Conformity. You will be asked to sign acceptance of the installation on this Certificate of Conformity.
- Note that your invoice for this appliance and this Certificate of Conformity is required in the event you wish to make a Warranty Claim. Please read carefully the specific warranty conditions on page 8.

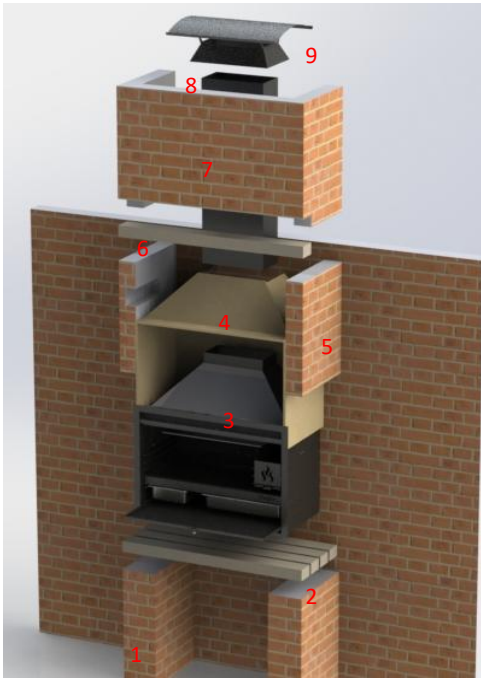

## 7.2 Important Information for the Registered Gas Installer

- LPG Models may only be installed by a Gas Installer registered with SAQCC GAS to install LP Gas appliances and Natural Gas appliances may only be installed by a Gas Installer registered by SAQCC Gas to install Natural Gas appliances. LPG appliances must be installed in accordance with SANS 10087-1 and Natural Gas appliances to SANS 827.
- **For LPG Units an approved gas regulator must be used set to a pressure of 28 Mbar**
- **For Natural Gas an approved gas regulator must be used set to a pressure of 20 Mbar.**
- **In the manufacturing process Primary Air is set for optimal combustion.**
- In addition, LPG and Natural gas installations must also comply with any local Fire department regulations and or local bylaws applicable to that area.
- If in doubt, check with the local authority before undertaking the installation. Upon completion of the installation, you are required to fully explain and demonstrate to the user the operational and safety practices applicable to the appliance and the installation, as well as issue a valid Certificate of Conformity for the installation work done.

- This appliance has been designed specifically for use with either only LPG or only Natural Gas, as marked on the appliance label/jet.
- It may not be used with any other gas than that for which it has been designed. Read these Installation & Operating Instructions carefully before commencing the installation.
- Should you suspect a leak at the gas cylinder (outside the house) then apply the soapy water solution to the visible joints such as where the regulator fits into the cylinder or where the regulator fits into the flexible hose, or the joints on the manifold if there is one fitted. If there is a leak, within the gas line then a bubble or bubbles will form. If you are unable to stop the leak at this point, then turn off the gas cylinder valve/s and call a Registered Gas installer to correct the fault.
- As with leaks inside the premises do not use the appliance until the Registered Gas Installer has declared that it is safe to do so.
- This appliance is fitted with an Oxygen Depletion Sensor and a Flame Failure Device, both of which are built into the Pilot Light Assembly. See figure 2. Do not interfere with, remove or modify these sensors.
- Do not place stones or any other objects against the Pilot Light Assembly, as this will prevent these sensors working correctly.
- Do not remove the model rating plate that is attached to your appliance.
- This contains important information in addition to the Model Number of the unit & Date of Manufacture, which the manufacturer will require should you need to make a Warranty Claim.
- In the event of a burn back, where the flame burns back to the jet, (generally the flame will make a noise a bit like a blow torch operating) immediately turn off the gas supply at the control valve.
- After ensuring the flame is extinguished, wait 60 seconds before re-lighting the appliance in the normal manner. Should the appliance again burn back, close the control valve and call a Registered Gas Installer to examine the appliance.
- Do not use the appliance again until the Registered Gas Installer has declared that it is safe to do so.

## 7.3 Gas Cylinders

- At maximum setting our gas burners consume 0.5 Kg/ hr each. Heat production peaks at about 6Kw per burner.

- However, this peak production is only required to heat the braai.
- Once it is hot enough to cook, you will adjust the heat output down to that required. Typical gas consumption whilst cooking will be 150 to 250 grams per burner per hour. This braai will therefore work on a minimum bottle size of 1 x 9Kg gas bottle.

#### 7.4 Lighting the appliance

- If at any time during the igniting process or during use, you smell un-burnt gas, immediately turn off the gas supply to the appliance, at both the control valve/s and the isolation valve/gas bottle.
- Do not use this appliance until it has been checked for leaks as described in section 6. It is preferable that this is done by a Registered Gas Installer. Switch on the gas supply (at gas cylinder or at units' isolation valve).
- Press and hold in the red button on the Continuous Spark Ignitor (Fig 1 Point B), then slowly Rotate the control valve for the RHS burner (Fig 1 Point A) anti-clockwise to maximum setting. The RHS burner should ignite within a few seconds. Release the red button. Once the RHS burner is lit, the LHS burner can be lit if required, by turning the control valve for this burner (Fig 1 Point C) to maximum setting.
- Note the LHS burner can only be lit if the RHS burner is already lit.
- The unit will take a few minutes to warm up to temperature to enable cooking to commence. Once the unit has reached desired temperature the heat can be turned down to that required by partially closing the control valves, by turning in a clockwise direction.

#### 7.5 Lighting the Appliance Manually

- In the event that the Continuous Spark Ignitor does not light the RHS burner, it can be lit using a long gas lighter or a long match.
- Hold the flame of the long lighter or long match next to the RHS burner and rotate the Control Valve for that burner anti-clockwise to the fully open position.

#### 7.6 Turning off the Appliance

- To turn off a burner, turn that burners control valve to fully closed. Turn fully clockwise.
- On completion of cooking the gas supply to the unit must be switched off, either by closing the tap on the gas bottle or by closing the units Isolator Valve (in the event the appliance is part of a multiple gas unit installation).

### 8. Safety Information

#### Keep young children away from the appliance when in use.

- These gas grills do not have flame failure devices built into the unit. As such, if the gas is left live to the unit, unlit gas can be vented from the unit if a control valve is inadvertently left open.
- When in use make sure there are no flammable materials close to the flames of the Appliance, above the appliance, or in contact/in close proximity with the rear, sides or base of the unit.
- Do not use this appliance if it is leaking gas. Never check for gas leaks with a naked flame or a spark, as this is extremely dangerous. If there is an apparent gas leak (smell of gas), close the control valve on the appliance and close the gas at the isolation valve/gas bottle. Make sure there are no naked flames within 5 metres of the appliance and check for leaks as detailed below.
- To check for a gas leak, use a brush dipped in a soapy water solution (e.g. water with dishwashing liquid added) and apply the solution to the joints in the system. With the gas supply switched on but the units Control Valves closed, if there are bubbles there is a leak. If there is a leak, then turn off the gas supply at the isolation valve/gas bottle. Call a Registered Gas Installer to examine the appliance and do not use the appliance until the service technician has declared that it is safe to do so.
- Should you suspect a leak at the gas cylinder then apply the soapy water solution to the visible joints such as where the regulator fits into the cylinder or where the regulator fits into the flexible hose, or the joints on the manifold if there is one fitted. If there is a leak, with the gas live, then a bubble or bubbles will form. If you are unable to stop the leak at this point, then turn off the gas cylinder valve/s and call a Registered Gas Installer to correct the fault.
- As with leaks inside the premises do not use the appliance until the Registered Gas Installer has declared that it is safe to do so.
- Do not remove the Model Rating Plate that is attached to your appliance. This contains important information in addition to the Model Number of the unit & date of manufacture, which the manufacturer will require should you need to make a Warranty Claim. In the event of a burn back, where the flame burns back to the jet, (generally the flame will make a noise a bit like a blow torch while operating) immediately turn off the gas supply at the control valve.

- After ensuring the flame is extinguished, wait 60 seconds before re-lighting the appliance in the normal manner. Should the appliance again burn back, close the control valve and call a Registered Gas Installer to examine the appliance. Do not use the appliance again until the Registered Gas Installer has declared that it is safe to do so.
- Never try to move any of the cooking grills/fat catcher/ flame tamer plates whilst they are hot or whilst the braai is lit. Users should become familiar with the normal flame patterns of the unit. Anything abnormal, switch the appliance off at the Control Valve/s. Wait 60 seconds and relight. If the abnormality continues, call a Registered Gas Fitter to examine the appliance.

## 9. Care & Maintenance

### 9.1 Cooking Grills

- Wash the Cooking Grills and brush/wipe with cooking/ olive oil prior to cooking to minimise meat sticking to the grills. This appliance is supplied with a Stainless-Steel Vee shaped grill cleaner to assist in getting fatty/burnt deposits off the grills. General cleaning of the cooking grills is best achieved by soaking the grills and then using a slightly abrasive cleaner (brillo pad/pot scourer).
- If need be, steel wool/scouring powder or fine sandpaper can be used to clean any well stuck on pieces from the stainless-steel grills.

### 9.2 Fat Catcher Tray

- All our Gas Grills have V shaped cooking grills that drain about 75% of the fat from the cooking meat away into an easily removable fat catcher tray.
- The remainder of the fat drops into the hot combustion area where it can burn and give your food that great braai smoke flavour. The reduced amount of fat burning means less flare up (flames from the fat burning) and less risk of burning the cooking meat.
- The fat catcher tray should be removed after each braai and cleaned. See Fig 3. Simply lift the cooking grills off, remove the Fat Catcher Tray by rotating the base of it slightly into the centre of the braai. Clean and replace.

### 9.3 Flame Tamer Plates

- Note that all Conversion & Multifunction gas grills come as standard with flame tamer plates. See Fig 3. The Flame Tamer Plates do not need to be cleaned on a frequent basis, as the heat of the braai will sanitise them and break away small deposits. Should you wish to give them a clean, they can be treated as per the Cooking Grills. In operation these plates will glow red with the heat, which will when cold leave these plates with a coppery colour. This is normal.

## 9.4 Drip Tray

See Fig 1 Part D

- Line the drip tray (under the braai) with aluminium foil to assist in cleaning. The Drip Tray will need taking out and cleaning with the frequency of this determined by how fatty the meats are being cooked.

## 9.5 Burners

- Our heavy-duty burners require little maintenance. It is recommended that after about a year of braaiing (about 100 braais) that the burners be removed, brushed well with a steel brush and tapped lightly with a hammer to remove any oxidation/ scaling, and are reinstalled. The unit comes with a 2-burner Gas Grill. H-shaped burners are heavy duty and operate in the range of 1 – 7 Kw. This offers a great variation in temperature, suiting multiple cooking techniques.

## 9.6 Replacing the Continuous Spark Ignitor Battery

- If the Continuous Spark Ignitor is not sending a steady stream of sparks onto the RHS burner, it will need a battery change. To replace the battery, simply unscrew anticlockwise the front of the ignitor, and remove the battery. Insert new battery and screw back on the front.

## 9.7 Servicing

- It is recommended that this appliance is serviced annually by a Registered Gas Installer. The gas installer should check the safe & efficient operation of the unit as well as the soundness of the gas line & regulator.
- It will ensure good cooking heat and well as the continued safe functioning of this appliance.

## 9.8 Major Overhauls

- Firefox offers a service of a complete overhaul of our Multibraai Gas Grills, which includes stripping/cleaning and where necessary replacing the Burners/Continuous Spark Ignitor etc, acid soaking the body of the braai, reassembling and re-polishing the unit.
- Please contact us if you wish to arrange this at our Pretoria factory.

## 9.9 Regulator

- No regulator is supplied with this unit.

**10. Gas grate information**

Model No.	MBMFGG	
No Burners	2 Burner	
Gas Type	LPG	NG
Operating Pressure	2.8Kpa	2Kpa
Gas Consumption on max setting	1Kg/hr	50MJ
No of Jets	2	2
Jet No	BE	BENG
Jet Size	1.5	2
Heat Output	12Kw	12Kw

**11. Images**

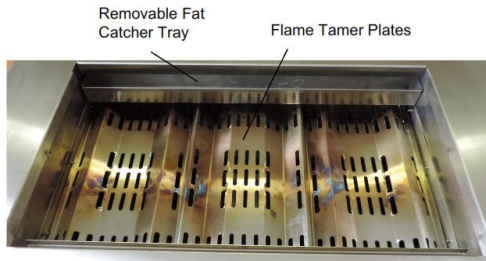

Fig. 3

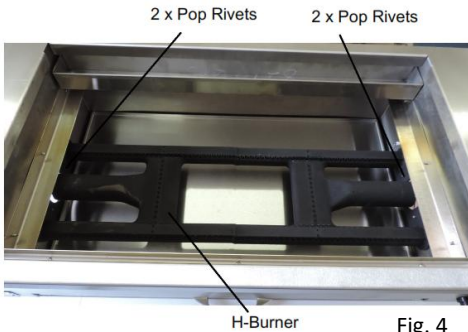
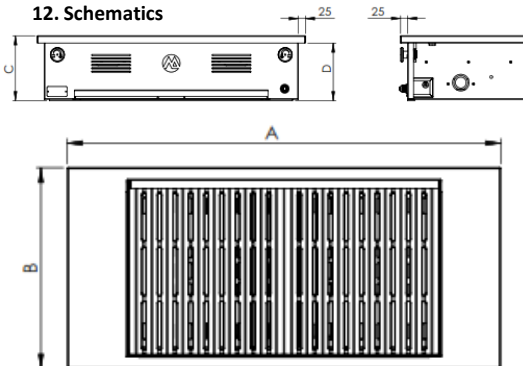

Fig. 4

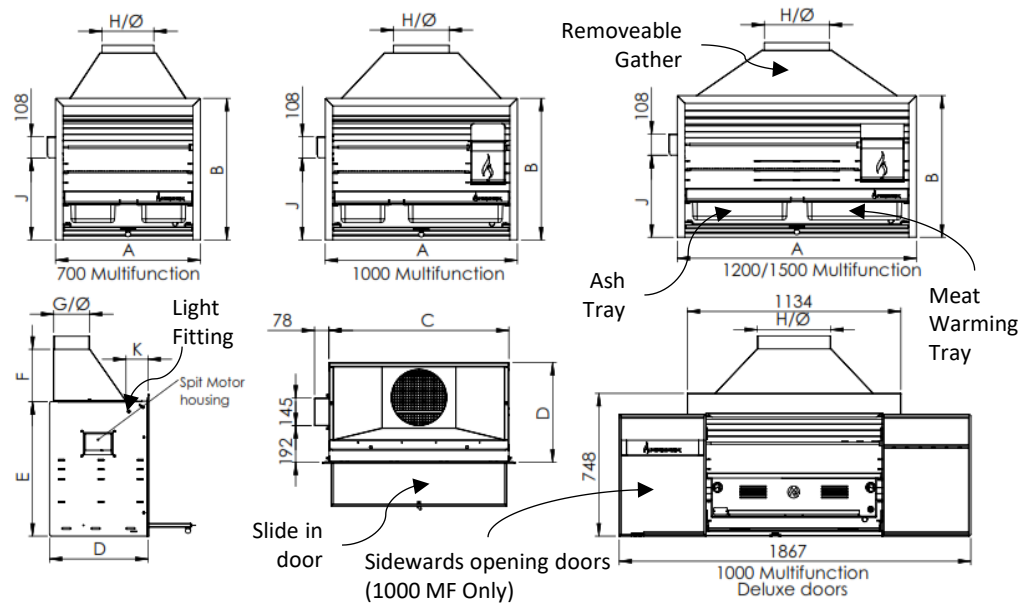

Fig 5.

**12. Schematics**



Description	1000 Multifunction
A	928
B	447
C	233
D	207



Product	A	B	C	D	E	F	G	H	Ø	J	K
700 Multifunction	770	742	705	523	708	273	200	300	275	430	117
1000 Multifunction	1020	742	955	523	708	273	200	400	300	430	117
1200 Multifunction	1270	742	1205	523	708	273	300	300	350	430	117
1500 Multifunction	1570	842	1505	703	808	220	350	500	450	430	225

### 13. BRAAI PRODUCTS WARRANTY

Infiniti Fires warrants the soundness of their Braai products for the period after purchase as detailed below.

- Built in Steel Braai Bodies & Frames/Table Braai Bodies 5 years
- Ember Makers/Ember Trays/Grids and other items directly in the flame path 1 year
- Spits, Spit Baskets, Warming Grids & Trays 2 years
- Electrical spit motors 1 year
- Gas Grilles 3 year

To validate the warranty, the customer must produce;

- Proof of Purchase, so that the purchase date can be verified.
  - In the event the unit is an installed/fixed Gas unit a copy of the Certificate of Compliance
- Fixed gas units are legally required to be installed by a Registered Gas Fitter, licensed by SAQCC for the type of gas being used. It is a legal requirement that this Gas Fitter provide a Certificate of Compliance on completion of the installation. You should keep this COC safe in case needed in future.

#### OUR WARRANTY DOES NOT COVER

- Corrosion where the product has been installed in a location or manner, such that, it is subject to water ingress or sea influence. Consult our document, Choice of Steel your Braai should be made from, located in our Braai, Gas grille and Smoke Extraction Product Directory.
- Damage to the Appliance, where it has not been installed in compliance with its Instruction Manual
- Damage caused by the Appliance operating outside of its normal working state.

If a claim arises under this warranty, Infiniti Fires will, at its sole discretion either repair or replace the affected unit.

As Infiniti Fires does not do the installation of these units, it accepts no responsibility for the installation thereof.

Infiniti Fires will not be responsible for any consequential damage arising from the use of its units.

### 14. IMPORTANT POINTS

This appliance is intended for outdoor use only. This appliance should not be modified/adjusted from its ex-factory specification.

This appliance has been supplied with either; Flame Tamer Plate(s)

Or

Rock tray(s) and Rocks.

To be located in the appliance above the burners.

See figs 2 & 3

Rocks should be installed above the rock tray in a manner and depth of rock, such that tips of the flames can easily penetrate above the rocks.

Do not pack rocks tightly or too high. Rocks packed too tightly or too high will cause sooting of the appliance and poor heat output.

Do not install rocks on top of the Flame Tamer Plates.

**Firefox (Pty) Ltd**  
 104 Van Tonder Street, Sunderland Ridge,  
 Centurion  
 P.O. Box 520 Fourways 2055  
 T (012) 666 9379  
[sales@firefox.co.za](mailto:sales@firefox.co.za)  
[www.firefox.co.za](http://www.firefox.co.za)