

This appliance conforms to the requirements of SANS1539  
LPGSASA Permit Number: 1011-9/2-RSA-17-A  
Drop-in Model Number: MB1DI, MB2DI, MB3DI



**Drop-in Gas Grills  
Installation & Operating Instructions**



**Please read these instructions carefully before installation and use, and retain them for future reference**

**Updated: 20 May 2026**

## INTENDED USAGE

This appliance is intended for use on open covered patios where there is a roof overhead, and a free flow of air across the patio. This free flow of air will enable adequate air supply to the unit for efficient combustion of the gas, as well as allow the safe dispersal of un-burnt gas, should the appliance be accidentally left with the gas valve in the open position, whilst the burners are not lit.

It may not be installed in patios that have doors/windows that can fully enclose the area, such that there is no free flow of air across the patio.

It may not be used inside a house/dwelling/office.

## CONTENTS

1. Introduction
2. Technical Data
3. Important Information for the User
4. Important Information for the Registered Gas Installer
5. Gas Cylinders Safety
6. Information Lighting
7. the Appliance
8. Lighting the Appliance Manually
9. Turning off the Appliance
10. Accessories
11. Care & Maintenance
12. Installing the Gas Grill onto a solid surface top
13. Reference Figures
14. Braai Options
15. Schematics
16. Warranty & Contact Details

## 1. INTRODUCTION

Thank you for purchasing your new Multibraai Gas Grill manufactured to the highest standards and tested in South Africa for compliance with the National Standard 1539. This appliance is designed to give the users years of trouble free and efficient service.

Please read the following instructions carefully.

Please note that this appliance must be installed by a Registered Gas Installer as indicated below. The manufacturer and/or its agents and distributors will not be held liable for injuries or damages caused by faulty or incorrect installation work.

## 2. TECHNICAL DATA

Model No	MB1		MB2		MB3	
No Burners	1 Burner		2 Burner		3 Burner	
Gas Type	LPG	NG	LPG	NG	LPG	NG
Operating Pressure	2.8Kpa	2Kpa	2.8Kpa	2Kpa	2.8Kpa	2Kpa
Gas Consumption on Max Setting	0.6Kg/hr	30MJ	1.2kg/hr	60MJ	1.8Kg/hr	90MJ
No of Jets	1	1	2	2	3	3
Jet No	BD	BDNG	BD	BDNG	BD	BDNG
Jet Size	1.7mm	1.7mm	1.7mm	1.7mm	1.7mm	1.7mm
Heat Output	7Kw	7Kw	14Kw	14Kw	21Kw	21Kw

### 3. IMPORTANT INFORMATION FOR THE USER

Read these instructions carefully before using the appliance and retain them for future reference. This appliance consumes oxygen when in use and it is important that it is only used in a well-ventilated area for the efficient performance of the appliance and the safety of the occupants of the area.

#### Trolley Braais

If a trolley braai is used as a portable appliance connected by a flexible hose to 1 x 9 Kg dedicated gas bottle, it requires no installation other than connecting to the gas bottle. This can be done by any competent person.

#### All Countertop/Drop In/Built In Gas Grills or Trolley Braais (installed other than detailed above)

These gas connections are regarded in terms of SANS 10087-1 as fixed installations and may only be installed by a Registered Gas Fitter.

All registered gas installers are issued with a driver's license size card, displaying their registration number, the type of gas they are registered to work on, and the expiry date of their registration. Ask to be shown this card before allowing the installation work to commence. Make a note of the Installer registration number, as well as verify that the gas type they are registered to work with, complies with the gas type you will be using. If there is any doubt on the registration of your chosen installer log onto [www.saqccgas.co.za](http://www.saqccgas.co.za) to look up their details.

Upon completion of the installation, the installer is legally required to explain the operational details of the appliance, together with the safety instructions, and is required to issue you a Certificate of Conformity. You will be asked to sign acceptance of the installation on this Certificate of Conformity. Note that your invoice for this appliance and this Certificate of Conformity is required in the event you wish to make a Warranty Claim. Please read carefully the specific warranty conditions on page 8.

### 4. IMPORTANT INFORMATION FOR THE REGISTERED GAS INSTALLER

LPG Models may only be installed by a Gas Installer registered with SAQCC GAS to install LP Gas appliances and Natural Gas appliances may only be installed by a Gas Installer registered by SAQCC Gas to install Natural Gas appliances. LPG appliances must be installed in accordance with SANS 10087-1 and Natural Gas appliances to SANS 827.

In addition, LPG and Natural gas installations must also comply with any local Fire department regulations and or local bylaws applicable to that area. If in doubt, check with the local authority before undertaking the installation. Upon completion of the installation, you are required to fully explain and demonstrate to the user the operational and safety practices applicable to the appliance and the installation, as well as issue a valid Certificate of Conformity for the installation work done.

This appliance has been designed specifically for use with either only LPG or only Natural Gas, as marked on the appliance label/jet. It may not be used with any other gas than that for which it has been designed.

For LPG Units an approved gas regulator must be used set to a pressure of 28 Mbar

For Natural Gas an approved gas regulator must be used set to a pressure of 20 Mbar.  
In the manufacturing process Primary Air is set for optimal combustion.

Read these Installation & Operating Instructions carefully before commencing the installation.

### 5. GAS CYLINDERS

At maximum setting our gas burners consume 0.6 Kg/hr each. Heat production peaks at about 7Kw per burner. However, this peak heat production is only required to warm the braai.

Once it is hot enough to cook, you will adjust the heat output down to that required. Typical gas consumption whilst cooking will be 150 to 250 grams per burner per hour.

This braai will therefore work on a minimum bottle size of 1 x 9Kg gas bottle.

### 6. SAFETY INFORMATION

Keep young children away from the appliance when in use.

These gas grills do not have flame failure devices built into the unit. As such, if the gas is left live to the unit, until gas can be vented from the unit if a control valve is inadvertently left open.

When in use make sure there are no flammable materials close to the flames of the Appliance, above the appliance, or in contact/in close proximity with the rear, sides or base of the unit.

Do not use this appliance if it is leaking gas. Never check for gas leaks with a naked flame or a spark, as this is extremely dangerous.

If there is an apparent gas leak (smell of gas), close the control valve on the appliance and close the gas at the isolation valve/gas bottle. Make sure there are no naked flames within 5 metres of the appliance and check for leaks as detailed below.

To check for a gas leak, use a brush dipped in a soapy water solution (e.g. water with dishwashing liquid added) and apply the solution to the joints in the system. With the gas supply switched on but the units Control Valves closed, if there are bubbles there is a leak. If there is a leak then turn off the gas supply at the isolation valve/gas bottle. Call a Registered Gas Installer to examine the appliance and do not use the appliance until the service technician has declared that it is safe to do so.

Should you suspect a leak at the gas cylinder then apply the soapy water solution to the visible joints such as where the regulator fits into the cylinder or where the regulator fits into the flexible hose, or the joints on the manifold if there is one fitted. If there is a leak, with the gas live, then a bubble or bubbles will form.

If you are unable to stop the leak at this point, then turn off the gas cylinder valve/s and call a Registered Gas Installer to correct the fault. As with leaks inside the premises do not use the appliance until the Registered Gas Installer has declared that it is safe to do so.

Do not remove the Model Rating Plate that is attached to your appliance. This contains important information in addition to the Model Number of the unit & date of manufacture, which the manufacturer will require should you need to make a Warranty Claim. In the event of a burn back, where the flame burns back to the jet, (generally the flame will make a noise a bit like a blow torch while operating) immediately turn off the gas supply at the control valve. After ensuring the flame is extinguished, wait 60 seconds before re-lighting the appliance in the normal manner. Should the appliance again burn back, close the control valve and call a Registered Gas Installer to examine the appliance. Do not use the appliance again until the Registered Gas Installer has declared that it is safe to do so.

Never try to move any of the cooking grills/fat catcher/ flame tamer plates whilst they are hot or whilst the braai is lit.

Users should become familiar with the normal flame patterns of the unit. Anything abnormal, switch the appliance off at the Control Valve(s). Wait 60 seconds and relight. If the abnormality continues, call a Registered Gas Fitter to examine the appliance.

## **7. LIGHTING THE APPLIANCE**

If at any time during the igniting process or during use, you smell un-burnt gas, immediately turn off the gas supply to the appliance, at both the control valve(s) and the isolation valve/gas bottle. Do not use this appliance until it has been checked for leaks as described in section 6. It is preferable that this is done by a Registered Gas Installer.

Switch on the gas supply (at gas cylinder or at units isolation valve).

Press and hold in the red button on the Continuous Spark Ignitor (Fig 1 Point B), then slowly Rotate the control valve for the RHS burner (Fig 1 Point A ) anti- clockwise to maximum setting. The RHS burner should ignite within a few seconds.

Release the red button.

Once the RHS burner is lit, the LHS burner can be lit if required, by turning the control valve for this burner (Fig 1 Point C) to maximum setting. Note the LHS burner can only be lit if the RHS burner is already lit.

The unit will take a few minutes to warm up to temperature to enable cooking to commence. Once the unit has reached desired temperature the heat can be turned down to that required by partially closing the control valves, by turning in a clockwise direction.

## **8. LIGHTING THE APPLIANCE MANUALLY**

In the event that the Continuous Spark Ignitor does not light the RHS burner, it can be lit using a long gas lighter or a long match.

Hold the flame of the long lighter or long match next to the RHS burner and rotate the Control Valve for that burner anti-clockwise to the fully open position.

## **9. TURNING OFF THE APPLIANCE**

To turn off a burner, turn that burners control valve to fully closed. Turn fully clockwise. On completion of cooking, the gas supply to the unit must be switched off, either by closing the tap on the gas bottle or by closing the units Isolator Valve (in the event the appliance is part of a multiple gas unit installation).

## **ACCESSORIES**

### **10.1 Regulator**

No regulator supplied with this unit.

### **10.2 Oven**

Standard on Trolley Braais, optional on Counter Top and Drop-in Grills.

Where an Oven has been taken, the Oven will perform as a warming drawer if the Drip Tray (Fig 4) under the burners is left in position. To attain higher temperatures in the oven, remove this Drip Tray. Note when the Drip Tray is removed some marinade/fat from the cooking food will drip into the oven area.

### **10.3 Braai Plate**

Where an optional Braai Plate has been taken, it is fitted by removing one of the cooking grills and inserting the Braai Plate. It is ideal for stir fries, frying bacon and eggs, fish, prawns... Our Braai Plates are supplied with Egg Rings to assist you in frying eggs.

### **10.4 Roasting Dome**

Our Roasting Dome fits on the No 2 or 3 Gas Grill, and helps speed up the braaing of meat, enabling you to roast or slow cook meat or smoke food.

When making use of the grill with the roasting dome, make sure to use flame tamer plates instead of the rock grid and stones, as the stones retain their heat for longer and as a result will cause difficulties in regulating the cooking temperatures.

### **10.5 Spit Motor**

Applicable only to models purchased with a Roasting Dome.

Models ordered together with the Roasting Dome can take any of the following options together with the spit motor.

### **10.6 Chicken Spit & Skewers**

Prepare 2 joints of meat on the rotisserie, each weighing up to 1.5kg, with ease.

### **10.7 Spit Basket**

Cook those chicken flatties, lamb chops or wors with minimal effort. Great when the host wants to spend time interacting with guests.

### 10.8 Deep Spit Basket

Prepare several small roasts at the same time.

### 10.9 Grill Soaker Tray

A lot of kitchen sinks are too small to soak our grills in. A grill soaker tray is sold as an optional extra should you require one.

## CARE & MAINTENANCE

### 11.1 Cooking Grills

Wash the Cooking Grills and brush/wipe with cooking/olive oil prior to cooking to minimise meat sticking to the grills. This appliance is supplied with a Stainless Steel Vee shaped grill cleaner to assist in getting fatty/ burnt deposits off the grills.

General cleaning of the cooking grills is best achieved by soaking the grills and then using a slightly abrasive cleaner

(brillo pad/pot scourer).

If need be, steel wool/scouring powder or fine sandpaper can be used to clean any well stuck on pieces from the stainless steel grills.

### 11.2 Fat Catcher Tray

All our Gas Grills have V shaped cooking grills that drain about 75% of the fat from the cooking meat away into an easily removable fat catcher tray. The remainder of the fat drops into the hot combustion area where it can burn and give your food that great braai smoke flavour. The reduced amount of fat burning means less flare up ( flames from the fat burning) and less risk of burning the cooking meat. The fat catcher tray should be removed after each braai and cleaned. See Fig 2 & 3. Simply lift the cooking grills off, remove the Fat Catcher Tray by rotating the base of it slightly into the centre of the braai. Clean and replace.

### 11.3 Flame Tamer Plates

Note that all Conversion/Multifunction Gas grills as well as those Counter Top, Drop In & Trolley Braais, supplied with a Roasting Dome come as standard with Flame Tamer plates. On our other gas grills, the client can opt for flame tamer plates or rocks. See Fig 2 & 3. The Flame Tamer Plates do not need to be cleaned on a frequent basis, as the heat of the braai will sanitise them and break away small deposits. Should you wish to give them a clean, they can be treated as per the Cooking Grills. In operation these plates will glow red with the heat, which will when cold leave these plates with a coppery colour. This is normal.

### 11.4 Rocks

The rocks will need occasional washing to remove any accumulated fats & dust from their surface. Place them in a bucket of hot soapy water and stir to remove the grease. Once clean, dry the rocks well prior to reinstalling/using them.

### 11.5 Drip Tray

See Fig 4.

Line the drip tray (under the braai) with aluminum foil to assist in cleaning. The Drip Tray will need taking out and cleaning with the frequency of this determined by how fatty the meats are being cooked.

### 11.6 Burners

Our heavy duty burners require little maintenance. It is recommended that after about a year of braaing (about 100 braais) that the burners be removed, brushed well with a steel brush and tapped lightly with a hammer to remove any oxidization/ scaling, and are reinstalled.

### 11.7 Replacing the Continuous Spark Ignitor Battery

See Fig 1 Part B

If the Continuous Spark Ignitor is not sending a steady stream of sparks onto the RHS burner, it will need a battery change. To replace the battery, simply unscrew anticlockwise the front of the ignitor, and remove the battery. Insert new battery and screw back on the front.

### 11.8 Servicing

It is recommended that this appliance is serviced annually by a Registered Gas Installer.

The gas installer should check the safe & efficient operation of the unit as well as the soundness of the gas line & regulator. It will ensure good cooking heat as well as the continued safe functioning of this appliance.

### 11.9 Major Overhauls

Firefox offers a service of a complete overhaul of our Multibraai Gas Grills, which includes stripping/cleaning and where necessary replacing the Burners/Continuous Spark Ignitor etc, acid soaking the body of the braai, reassembling and re-polishing the unit. Please contact us if you wish to arrange this at our Pretoria factory.

## 12. INSTALLING THE GAS GRILL ONTO A SOLID SURFACE TOP

When installing, make sure to exactly follow the cut out dimensions given on page 8.

Take special care to not have any sort of chipboard or combustible material installed too close to the gas grill body, as this gets hot during use. This applies especially to the front of the gas grill underneath the counter top where the hot air escape vents are located. See Fig. 4. To keep the cavity underneath the gas grill cool, install either two louvers, at the bottom and top of the cupboard door, or, when installed against an external wall, place a louver at the top of the cupboard door and an air brick in the external wall.

See Fig. 7. The louvers/openings will also allow sufficient air supply to enter the underside of the gas grill. This is essential for the unit to work effectively and safely.

In the event that you decide not to use louvers in the cupboard construction process, you will need to make provision by acceptable methods, for an equivalent flow of air to the underside of the grate. In total an opening of about 32 000m<sup>3</sup> is required. Never put any combustible material in front of the Hot Air Escape Vents as this will create a possible fire hazard. If the counter-top needs to be supported, rather use a non-combustible material e.g. metal.

### 13. REFERENCE FIGURES

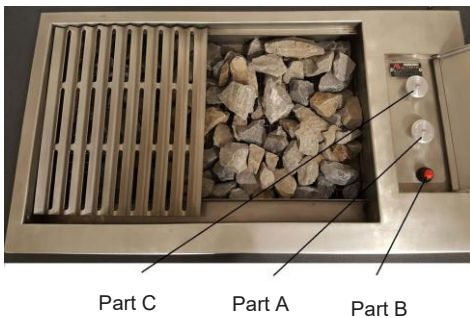
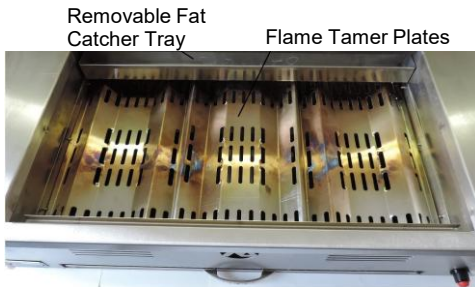

Fig 1.



Stones      Removable Fat Catcher Tray      V-Grills

Fig 2.



Removable Fat Catcher Tray      Flame Tamer Plates

Fig 3.

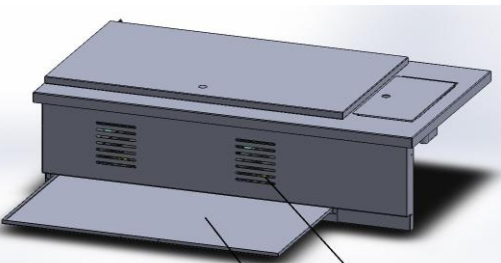

Drip Tray      Hot Air Escape Vents

Fig 4.



Pop Rivets to loosen gas burners

Fig 5.



Gas Inlet Compression Fitting Fig 6.

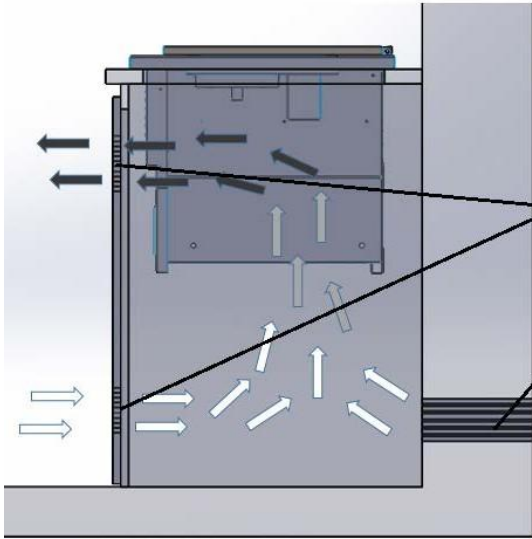

Louvers at the top and bottom of the door

Air Brick or opening with louvers in masonry wall

Fig 7.

Image shows how air brick and/or louvers help keep the cupboard cavity underneath the Drop-In grill cooler.

### 13. BRAAI OPTIONS

Images showing Counter Top & Trolley models.



Shallow Basket



Stainless Steel Braai Plate



Deep Chicken Basket



Spit & Chicken Skewers

## 15. Schematics

### 15.1 Counter Top

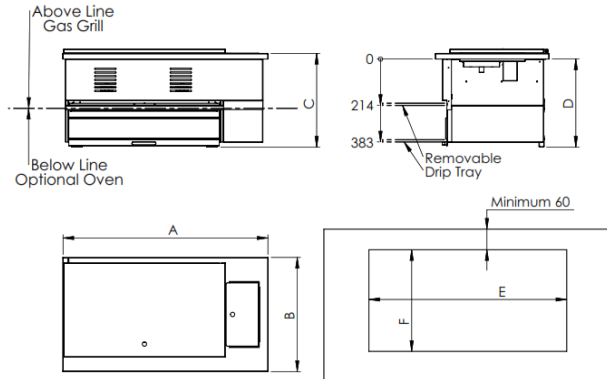

Drop In Gas Grills				Cut out sizes	
A	B	C	D	E	F
672	525	407	400	649	480
950	525	407	400	927	480
1300	525	407	400	1277	480
672	525	237	225	649	480
950	525	237	225	927	480
1300	525	237	225	1277	480

## 15.2 Roasting Dome Fits No 2&3 Gas Grill

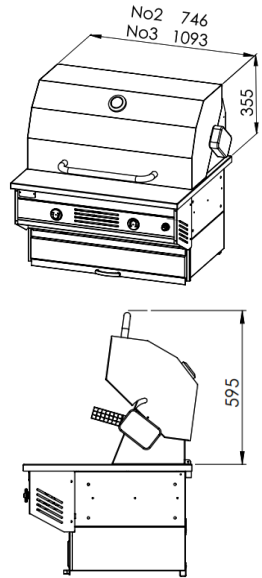

## 14. BRAAI PRODUCTS WARRANTY

Infiniti Fires warrants the soundness of their Braai products for the period after purchase as detailed below.

Built in Steel Braai Bodies & Frames/Table Braai Bodies	5 years
Ember Makers/Ember Trays/Grids and other items directly in the flame path	1 year
Spits, Spit Baskets, Warming Grids & Trays	2 years
Electrical spit motors	1 year
Gas Grilles	3 year

To validate the warranty, the customer must produce;

- Proof of Purchase, so that the purchase date can be verified.
- In the event the unit is an installed/fixxed Gas unit a copy of the Certificate of Compliance Fixed gas units are legally required to be installed by a Registered Gas Fitter, licensed by SAQCC for the type of gas being used. It is a legal requirement that this Gas Fitter provide a Certificate of Compliance on completion of the installation. You should keep this COC safe in case needed in future.

### OUR WARRANTY DOES NOT COVER

- Corrosion where the product has been installed in a location or manner, such that, it is subject to water ingress or sea influence. Consult our document, Choice of Steel your Braai should be made from, located in our Braai, Gas grille and Smoke Extraction Product Directory.
- Damage to the Appliance, where it has not been installed in compliance with its Instruction Manual.
- Damage caused by the Appliance operating outside of its normal working state.

If a claim arises under this warranty, Infiniti Fires will, at its sole discretion either repair or replace the affected unit.

As Infiniti Fires does not do the installation of these units, it accepts no responsibility for the installation thereof.

Infiniti Fires will not be responsible for any consequential damage arising from the use of its units.

## 15. IMPORTANT POINTS

This appliance is intended for outdoor use only. This appliance should not be modified/adjusted from its ex-factory specification.

This appliance has been supplied with either; Flame Tamer Plate(s)

Or

Rock tray(s) and Rocks.

To be located in the appliance above the burners.

See figs 2 & 3

Rocks should be installed above the rock tray in a manner and depth of rock, such that tips of the flames can easily penetrate above the rocks.

Do not pack rocks tightly or too high. Rocks packed too tightly or too high will cause sooting of the appliance and poor heat output.

Do not install rocks on top of the Flame Tamer Plates.

**Firefox (Pty) Ltd**  
**104 Van Tonder Street, Sunderland Ridge,**  
**Centurion**  
**P.O. Box 520 Fourways 2055**  
**T (012) 666 9379**  
[sales@firefox.co.za](mailto:sales@firefox.co.za)  
[www.firefox.co.za](http://www.firefox.co.za)